

Let's start on the seat next. We have already cut the pieces for the front, but these will be the last pieces we install, however we can go ahead and glue the three 2" wide pieces together to form the "I". From your 1x stock you will need to cut three pieces 9" x 9", one for the Top and two for the Sides, and one piece 7 1/2" x 9" for the Back. Glue the Back inside the two Sides. Strike pencil lines from corner to corner diagonally, on the underside of the Top to find center. Screw the 1 1/2" flange centered on this mark and then glue the Top to the sides and back. Before you attach the front, screw the 10" long 1 1/2" pipe into the flange. Then glue in the front and when it sets up we can start installing the lever arms.

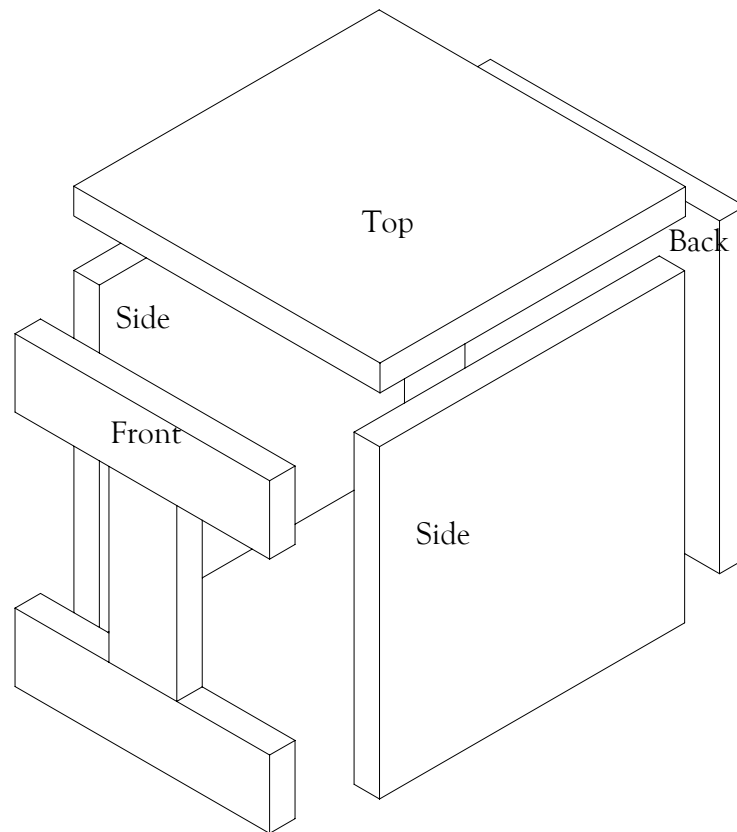

Turn the seat upside down, take one of your 18" pieces, stick it in trough the window formed by the front pieces. Put the squared end up against the Back and land the bottom corner 1 1/2" from the bottom edge. Rotate the front edge down until it is 3" down at the inside of the Front. Drill 1/4" holes through the center of the levers 2 1/2" in from the Front and Back. Insert 2" long 1/4" carriage bolts.

