

Now that the Handle with the spacer and arm glued together has had time to dry, we can start assembling the lever mechanism. Take a 1/8" drill bit and pilot all the ends of the dowel you cut, centering the hole as best you can. Using #6 3/4" zinc wood screws, attach a 1 1/4" fender washer to one end of each piece of dowel. Put your seat on the base, sliding the 1 1/2" pipe over the 1" pipe on the base. As you are facing the seat, start sliding the long dowel from the right hand side, after it goes through the first arm, put a spacer on, then put the one hole handle with the space and 21" arm glued to it on, handle first then glued on spacer, then the 21" arm, then a spacer then the other handle, then another spacer, finally through the other bolted on arm and cap it with another fender washer.

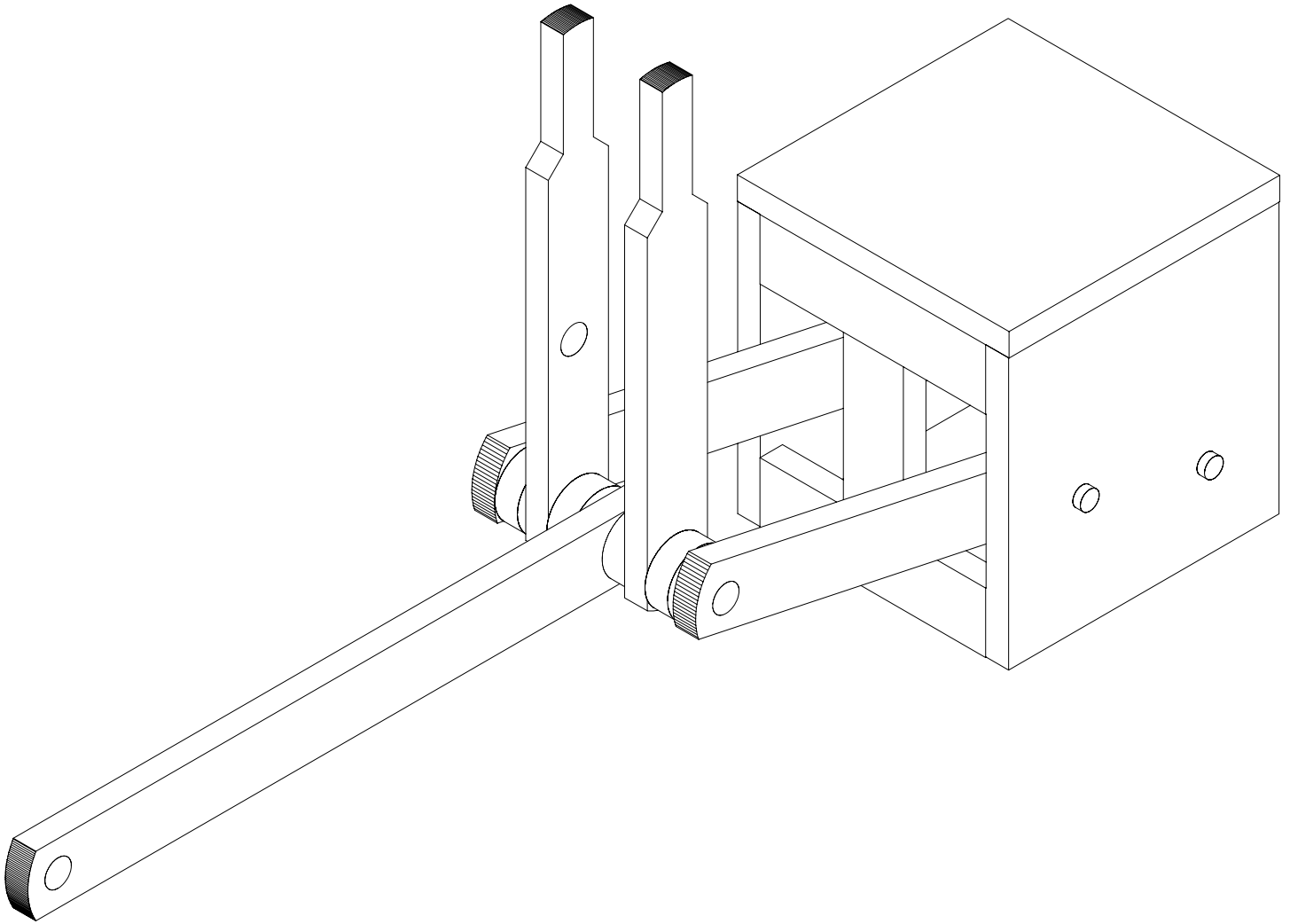

Next take one of the shorter dowels, insert it through the other handle from the outside, then add a spacer, then one end of the 19 1/2" arm. Cap it with a washer. Then put the other two dowels through the holes in one of the 9 1/2" pieces, then through the other ends of the 21" and 19 1/2" arms, then the other 9 1/2" piece, then cap both of them.