

Valley fold a third of the way down.

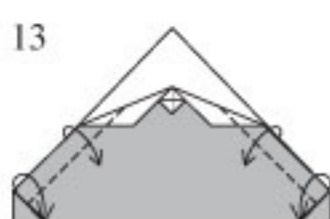

Valley-fold.



Valley-fold a single layer. On the left and right, reverse-fold the interior layer.

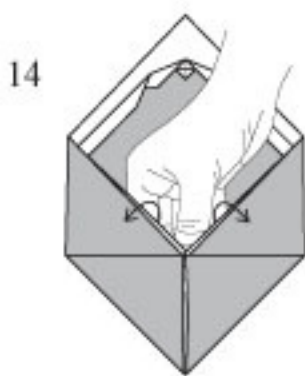

Insert your hand into the pocket, bringing the model into a three-dimensional shape.

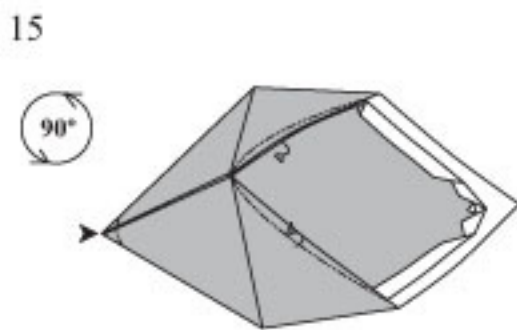

Closed-sink the left point. Mountain-fold the raw edges using curved folds.

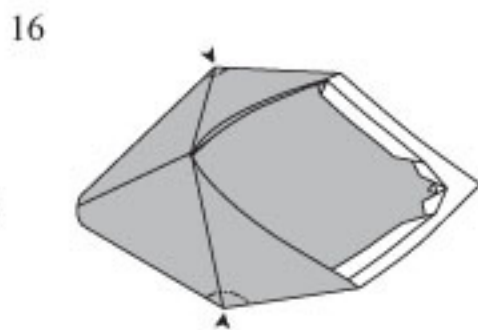

Closed-sink the two corners.

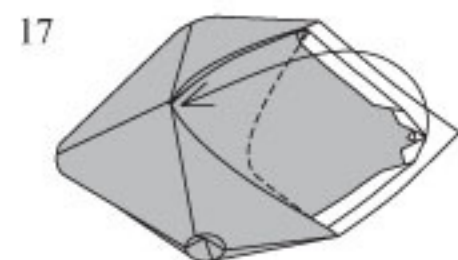

Valley-fold the jaw flap making a curved fold. The more curved the flap, the more round the back will be.

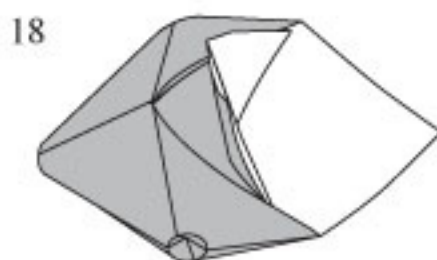

Turn over.

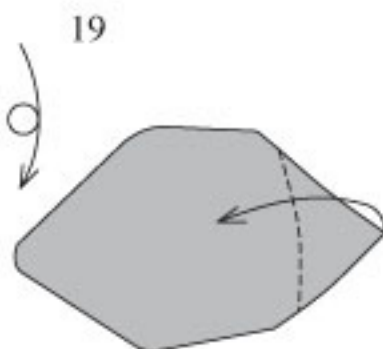

Valley-fold.

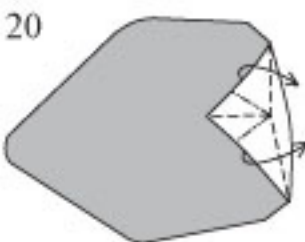

Rabbit-ear the flap to taste.

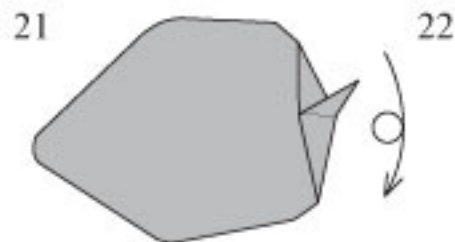

Turn over.



Shark Attack! Holding at the sides as shown, push your hands together and the jaws will shut. Adjust the curved valley-fold in step 17 to optimize the jaw movement.