

Folded Butterfly Page

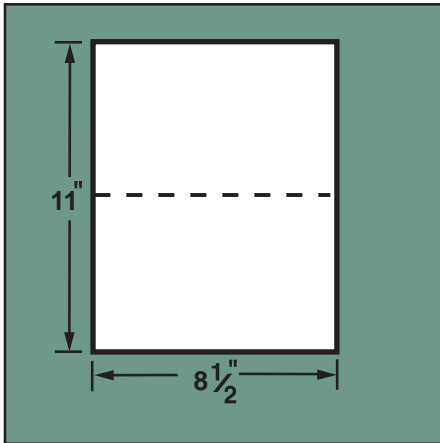

1. Start with an 8-1/2" x 11" sheet of acid-free paper.

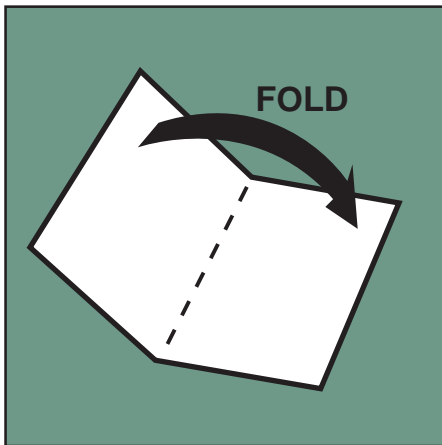

2. Fold the paper in half, making a center crease, then unfold.

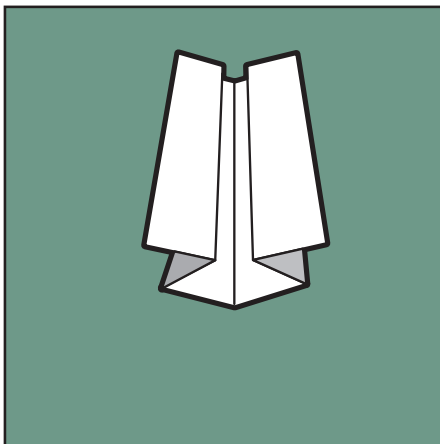

3. Using the center crease as a guide, fold each half of the paper in half again, bringing the new folds in to meet the original center fold.

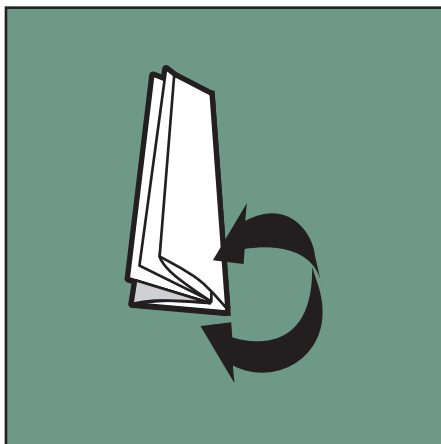

4. Without unfolding the new creases, fold the center crease again, this time in the same direction as the other two folds. Crease folds well and keep them intact.

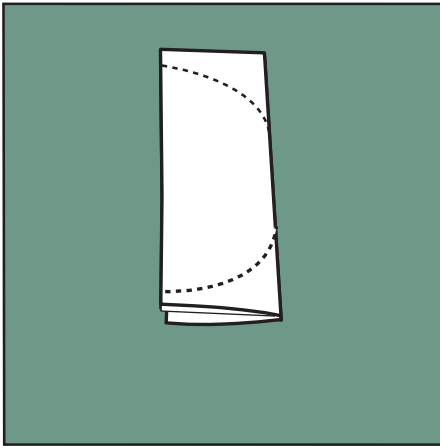

5. Working on the side of the accordion that has three folds, measure along the fold line, two inches up from each corner; make a light mark at those points. Using the marks as a starting point, make a diagonal convex curve cut to the corners on the opposite side of the accordion. After cutting, the accordion-folded paper should resemble a canoe.

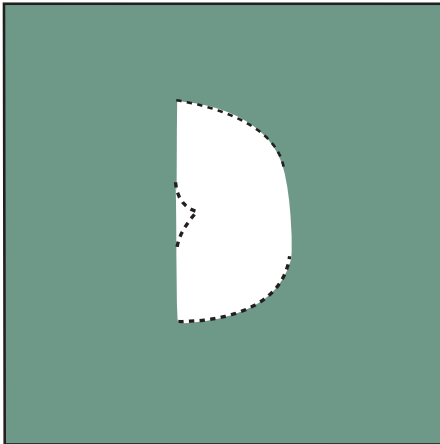

6. Working on the opposite side of the accordion (the uncut side with two folds), measure along the fold line from one corner, making a mark at 4-1/2 inches. Use scissors to notch out a V-shape centered at this mark.

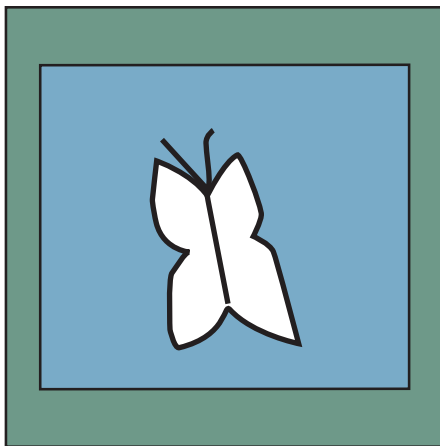

7. Unfold the center fold to reveal the butterfly shape. Mount on a scrapbook page. Embellish with antennae if desired, mounting them behind the butterfly.

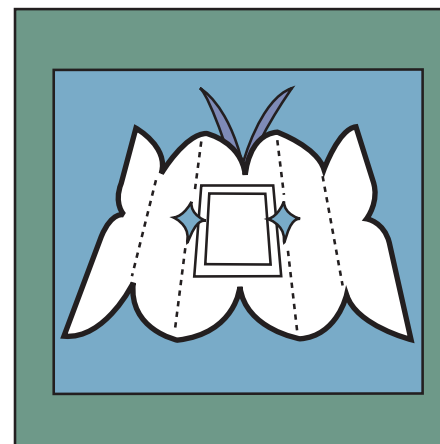

8. Unfold both sides of the wings to mount a photo.